

SEETRONIC

Product Data Sheet

Product Type **Power Plug**

Product Model **SAC3FCA**

Customer Name

Manufacturer	Prepared	Checked	Approved

Customer	Received	Checked	Confirmed



Product Data Sheet

Product Type	Power Plug	
Product Model	SAC3FCA	
Product Features		
<ul style="list-style-type: none">➤ Lockable three-core power-in cable connector with contacts for line, neutral and pre-adapted safety grounding➤ Non-waterproof, suitable for indoor use application➤ Match with SAC3MCA plug or SAC3MPA/SAC3MPA-M socket➤ Fast and easy locking system with firm latch lock which does not fall off➤ High current capacity rated at 20A/250V AC➤ UL Certification No. E359036➤ VDE Certification No. 40044166		



Product Data Sheet

Electrical Parameters

Item	Specification
Number of Contact	2 + PE
Rated Current	20 A
Rated Voltage	250V AC
Contact Resistance	$\leq 5 \text{ m}\Omega$
Dielectric Strength	4000V DC
Insulation Resistance	$> 1000 \text{ M}\Omega$

Mechanical Parameters

Item	Specification
Service Life	> 1000 mating cycles
Cable Size	2.5 mm^2
Cable OD	White strain relief: $\Phi 8-11 \text{ mm}$ Black strain relief: $\Phi 11-12 \text{ mm}$
Type of Terminals	Screw type terminals



Product Data Sheet

Material and Environmental Parameters

Item	Specification
Housing	PA
Contacts	Cu alloy
Contact surface	Ag
Flame retardant rating	UL94-V0
Temperature range	-30°C ~ +80°C

Standards and Certifications

Standards	UL1977 IEC61984 IEC60320-1 GB/T 34989
Certifications	UL: E359036 VDE: 40044166 TUV: N8A1083360006 CQC:CQC23003410678



Product Data Sheet

Product Drawing

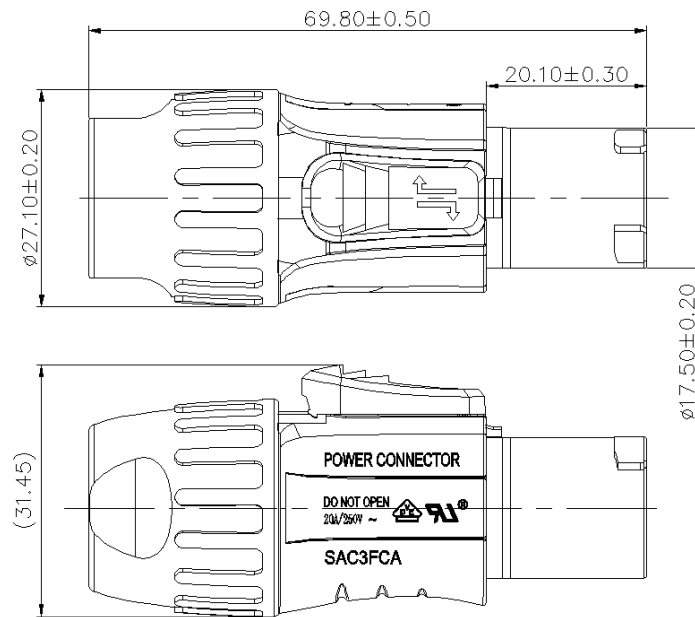

Unit: mm

Packaging Method

1 pc per bag (include 1 pc each of inner core, housing, black and white strain relief, bushing)
40 pcs per inner carton, 5 inner cartons per master carton (200 pcs per master carton)

Accessory

- | | |
|--|--|
| <input checked="" type="checkbox"/> No accessories | <input type="checkbox"/> Back fastener plate |
| <input type="checkbox"/> Screws and Nuts | <input type="checkbox"/> Other |



Product Data Sheet

Assembly Instructions

(1) Put the cable through the bushing and strain relief

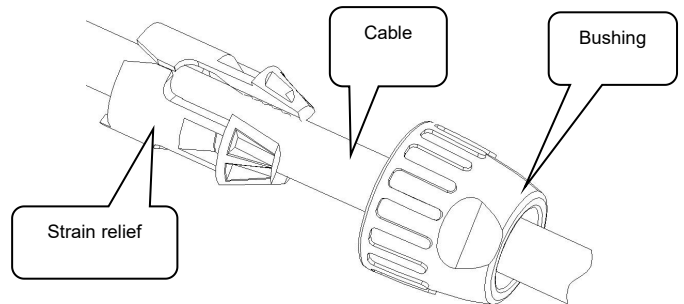

(2) Strip the cable in the size as shown

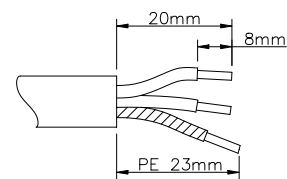

(3) Insert the conductor of the cable into the terminal of the inner core (refer to the wiring method on the right) and then lock with a torque of 0.5 Nm.

Wiring	VDE	UL
L	Brown	Black
N	Blue	White
Ground	Green/Yellow	Green

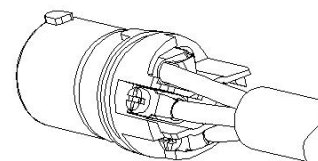

Product Data Sheet

Assembly Instructions

- (4) Push the inner core component into the housing with the strain relief. The protruding rib of strain relief should correspond to the protruding rib of inner core component. And the two protruding ribs should correspond to the two grooves inside the housing.

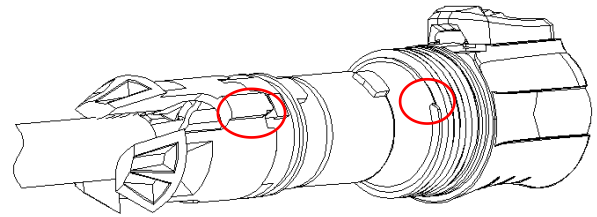

- (5) After assembly of the strain relief, inner core component and housing, tighten the bushing in a clockwise direction with a torque of 2.0 Nm.

